

## **A NEW APPROACH OF APPLYING CRYOGENIC COOLANT IN TURNING AISI 304 STAINLESS STEEL**

*A.A. Khan, M.Y. Ali and M.M. Haque*

Department of Manufacturing and Materials Engineering  
International Islamic University, Malaysia, P.O. Box 10, 50728 Kuala Lumpur  
Email: mmyali@iiu.edu.my

Received 7 March 2010, Accepted 13 September 2010

### **ABSTRACT**

In the present study a special device has been designed to apply liquid nitrogen coolant during turning of AISI 304 stainless steel. The base of the device is a magnet and it can be fixed at any suitable position on the tool or tool post. A long flexible and adjustable copper nozzle is used to apply liquid nitrogen at any angle or from any position. Experiments with three positions of the copper nozzle were performed. The results of the investigations showed that the most effective way to apply liquid nitrogen directly to the machining zone without any interference by the chips. Tool life increased four times compared to dry machining under this condition. The next effective way was to apply liquid nitrogen along the principal cutting edge. It was found that application of liquid nitrogen coolant did not improve job surface finish, but all the three positions of the copper nozzle demonstrated almost similar effectiveness.

**Keywords:** Cutting tool; AISI 304 steel; Liquid nitrogen, Cryogenic cooling

### **1. INTRODUCTION**

During metal cutting operations heat is generated due to (i) deformation of metal, (ii) sliding friction of the chip at the tool rake surface, and also (iii) the friction between the workpiece and the tool flank. This heat increases the temperature of the tool and reduces its hardness and hence tool life. High temperature may also cause some adverse effects like dimensional inaccuracy, poor surface finish, etc. Therefore, use of cutting fluid during machining operation is essential. Water soluble fluids are found to be suitable for operations where cutting speeds are very high and pressure on the tool is relatively low (Yakup and Muammer, 2008; Jaharah, et al., 2009). However, it was determined that cutting fluids cannot penetrate the chip-tool interface when the cutting speed is very high (Shaw, 1986). High pressure jet cooling is an effective way to reduce cutting temperature. A longer tool life was observed when machining Ti-6Al-4V with high pressure coolant supplies and the recorded surface roughness values were found to be below the tool rejection criteria [Ezugwn et al., 2007; Gill et al., 2010]. Though high-pressure coolant supply exhibits significant

improvement in tool life and surface finish, there are some drawbacks such as water pollution and soil contamination if disposed without proper treatment. Proper rules and regulations are to be followed for handling and disposal of used cutting fluids. High pressure cutting fluid also requires extra floor space, chilling and recycling of coolants (Dhar et al., 2002; Vadivel and Chattopadhyay, 20027). In addition, application of conventional cutting fluids in industries creates several health and environmental problems (Baradie, 1996). Therefore, researchers were looking for an environmentally friendly coolant for metal cutting. In 1950 liquid nitrogen has been used as a coolant in metal cutting industries and it was found to provide increased tool life, improved chip breaking, higher productivity, and healthier environment for the operator (Hong, 2001; Dhar and Kamruzzaman, 2007; Dhar et al., 2001; Kalia, 2010). Improvement of chip breakability has been achieved by reducing the chip temperature to the embrittlement temperature of ductile AISI 1008 workpiece material (Hong et al., 1999; Hong and Ding, 2001; Suleiman et al., 2009). Some techniques have been developed to apply cryogenic coolant such as a special chamber between the tool insert and the shim for liquid nitrogen. The insert and the cutting edge was cooled by heat conduction (Hong and Ding, 2001a). Cryogenic coolant can also be supplied by spraying on the tool insert. But in such an application coolant would also cool the unwanted areas like the workpiece that would increase the hardness of the workpiece and hence the cutting forces (Zurecki, 2003). Micro-nozzles to apply liquid nitrogen along the tool flank as well as through a hole in between the tool rake face and the chip breaker was also used (Hong et al., 2001). It facilitates chip breaking, but the system is complicated. In addition, a circulating system of liquid nitrogen through a tool cover placed at the top of the tool insert and reported significant increase of tool life (Wang et al., 2000). However, these systems are not flexible in applying cryogenic coolant. In the present work a new and special device has been designed that can be fixed at any convenient position on the tool or the tool post. Then liquid nitrogen can be applied from any direction with respect to the cutting edge. This new systems allow the operator to apply the liquid nitrogen conveniently along

or perpendicular to the cutting edge to avoid any other interference from chips.

## 2. METHODOLOGY

In the present study AISI 304 stainless steel was used as work material. The properties of the work material are listed in Table 1 (SubsTech, 2010). The experiments were conducted on a Harrison M390 lathe machine using coated carbide tool insert (Korloy HA-NC9020) as shown Figure 1. This insert is suitable for high speed cutting of stainless steels, low carbon steels, and aluminum. A special device shown in Figure 2 was developed to apply liquid nitrogen cutting fluid. It can be fixed to any suitable position on the tool or the tool post. The device was connected to the hose pipe of liquid nitrogen tank. A long copper nozzle of 1 mm inside diameter was soldered to the connector. Since the copper nozzle was thin, it was flexible and could be bended and adjusted to apply liquid nitrogen from any angle or from any position with respect to the cutting edge. Heat transfer from the copper nozzle to the surrounding was prevented by insulation as shown in Figure 2. Three positioning of the nozzle was tried in the present experimental study as shown in Figure 3. During conducting the experiments cutting speed, feed rate and depth of cut were kept constant at 180 m/min, 0.2 mm/rev and 1 mm respectively. During dry machining the tool flank wear was measured after each 2 minutes of machining and during machining with cryogenic coolant the same was measured after each 4 minutes of machining. Tool flank wear was measured using a profile projector Mitutoyo PJ311. The work surface roughness was measured periodically to determine the relationship between job surface roughness and machining time. Mitutoyo PC based surface roughness equipment SV-500 was used for this purpose.

## 3. RESULTS AND DISCUSSIONS

In this section the tool wear and surface finish due to cryogenic turning using liquid nitrogen are discussed. The results of dry cutting and cutting with liquid nitrogen cutting fluid are compared to find the relative advantages.

### 3.1. Tool Wear

Growth of flank wear with time for dry machining and cryogenic machining with different positions of the nozzle is illustrated in Figure 4. Tool life for dry machining and cryogenic machining with nozzle positions 'a', 'b' and 'c' are 28 min, 104.7 min and 115.3 min respectively. It shows that the application of cryogenic coolant has enhanced tool life by more than four times. It was also stated that tool life increased 4.7 times when liquid nitrogen was applied through a hole in the tool holder (Khan and Ahmed, 2010). In the present investigation the maximum tool life was found during application of coolant from the position 'c'. If the coolant is applied from the bottom of the machining zone, it

directly cools the cutting edge without being disturbed by the chip. As a result tool wear is reduced.

Table1. Selected properties of AISI 304 stainless steel (SubsTech, 2010)

Properties	Values
Composition (%)	Cr: 18-20, Ni: 8-10.5, MN: 2, Si: 1, C: 0.8, P: 0.04, S: 0.03
Yield strength (MPa)	207
Tensile strength (MPa)	517
Elongation (%)	40
Reduction (%)	60
Hardness (HB)	187

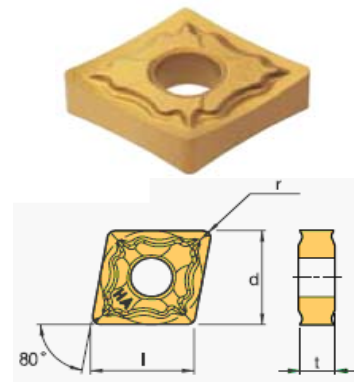

Figure 1 Coated carbide tool insert.  $l = 12.9$  mm;  $d = 12.7$  mm;  $t = 4.76$  mm and  $r = 0.8$  mm.

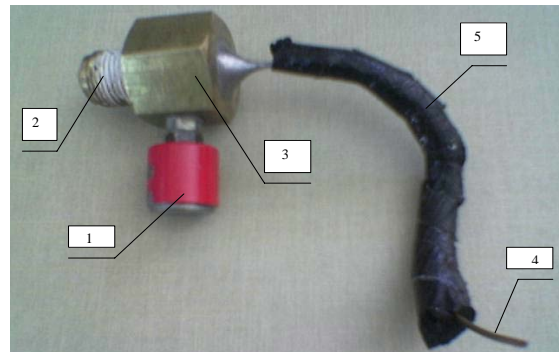

Figure 2 Device to apply liquid nitrogen (1: magnetic base; 2: threaded end; 3: connector; 4: copper nozzle; 5: thermal insulation)

The next good performance was found for the position 'a' that is the coolant is applied along the principal cutting edge. It cools the principal cutting edge which is heated to a higher temperature compared to the auxiliary cutting edge. But if the coolant is applied perpendicular to the principal cutting edge as in the position 'b', it blows away the hot chip from the tool face and reduces the contact between the hot chip and the tool face. In this case cryogenic coolant mainly cools the chip and is less

effective in cooling the cutting edges. Figure 5 illustrates the flank wear of the inserts at different cooling conditions.

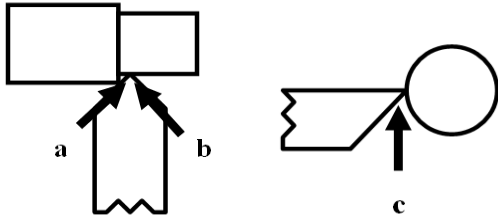

Figure 3 Three different positions for applying liquid nitrogen cutting fluid **a**: on the tool face along the principal cutting edge, **b**: perpendicular to the principal cutting edge, **c**: from the bottom through the gap between the tool flank and the workpiece.

Figure 5 (i) shows the complete damage of the cutting edges due to dry machining, whereas Figure 5 (iv) shows a little wear along the flank. This little flank wear occurred when cryogenic coolant was introduced from the bottom of the machining zone (position c). Figure 5 (iii) shows a breakage of the cutting edge after 28 minutes of machining when cryogenic coolant was introduced perpendicular to the cutting edge (position b). Figure 5 (ii) shows a large rubbing marks along the flank, but without any breakage of the cutting edge (position a).

### 3.2. Surface Finish

Effect of cryogenic cooling with different positions of the nozzle on job surface finish is not very significant as can be seen from Figure 6. Cryogenic cooling in one hand reduces tool wear and rubbing of the flank with the work surface that should produce a better surface. On the other hand, due to cooling, the hardness of the work material increases resulting increase in cutting force and vibration that produce poorer surface.

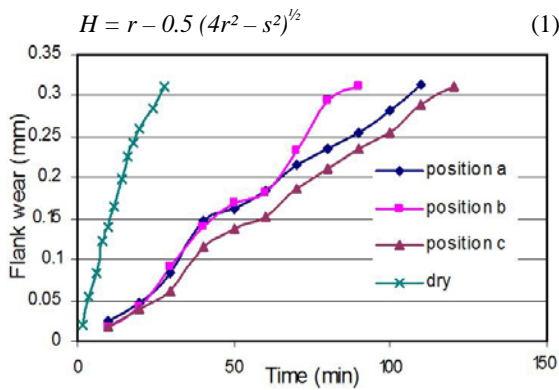

Figure 4 Growth of flank wear with machining time and cryogenic cooling from different direction.

Due to these dual effects of cryogenic cooling, the ultimate effect is not significant on job surface roughness. However, job surface roughness is much higher during dry machining compared to cryogenic

cooling. Cryogenic cooling reduces tool wear that prevents the work surface from rubbing with the tool flank.

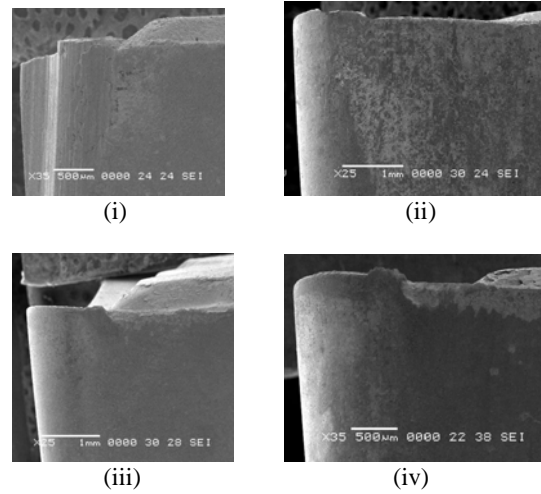

Figure 5 Scanning electron microscope (SEM) images of the flank of the tool inserts after a machining time of 28 minutes at different cooling conditions as shown in Fig.

3. (i) Dry machining without any coolant, machining with liquid nitrogen coolant directing (ii) on the tool face along the principal cutting edge, (iii) perpendicular to the principal cutting edge, (iv) from the bottom through the gap between the tool flank and the workpiece

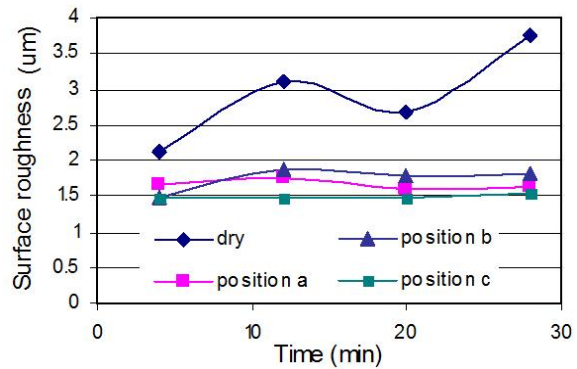

Figure 6 Relationship of surface roughness and machining time for different cooling conditions

This results smoother job surface during cryogenic cooling compared to dry machining. The best surface was obtained during cooling with nozzle position 'c' followed by the nozzle positions 'a' and 'b'. During cryogenic cooling all the positions of the nozzle considered are almost equally effective. Initially the sharpness of the tool reduces in course of machining time resulting more rubbing of the flank with the work surface. As a result work surface roughness increases. But as the machining goes on, the nose radius of the tool also increases. The relationship of surface roughness with nose radius of the tool is given by the mathematical expression Eqn (1). This equation shows that job surface roughness reduces with increase of nose radius of the

tool. Therefore, job surface roughness was found to reduce within the machining time ranging from 12 minutes to 20 minutes. But after 20 minutes of machining, tool wear dominates the factor of increasing nose radius and the surface becomes rougher.

#### 4. CONCLUSIONS

1. A special device has been designed that is very convenient to apply cryogenic coolant. It can be fixed at any convenient position on the tool or the tool post. The flexible copper nozzle can be bent and adjusted to apply coolant from any direction with respect to the cutting edge.
2. Cryogenic cooling significantly improved tool life. In the present work the improvement was found to be 4 times of dry cutting.
3. The position 'c' (Fig. 3) was found to be the most effective position of applying cryogenic coolant. When the coolant is applied from the bottom through the gap between the tool flank and the workpiece, it directly cools the machining zone and is not interrupted by the chips. The next effective position of the nozzle was position 'a' followed by the position 'b'.
4. Application of cryogenic cooling did not improve work surface finish. All the positions of the nozzle are almost equally effective, though the position 'c' of the nozzle exhibits a better surface finish followed by position 'a' and 'b'.

#### REFERENCES

- Baradie, M. A. E., 1996 Cutting fluids: Part II. Recycling and clean machining, *Journal of Material Processing Technology*, 56(1-4), 798-806.
- Dhar, N. R. and Kamruzzaman, M., 2007. Cutting temperature, tool wear, surface roughness and dimensional deviation in turning AISI-4037 steel under cryogenic condition, *International Journal of Machine Tools and Manufacture* 47(5), 754-759.
- Dhar, N. R., Paul, S. and Chattopadhyay, A. B., 2001. The influence of cryogenic cooling on tool wear, dimensional accuracy and surface finish in turning AISI 1040 and E4340C steels, *Wear* 249(10-11), 932-942.
- Dhar, N. R., Paul, S. and Chattopadhyay, A. B., 2002. Machining of AISI 4140 steel under cryogenic cooling – tool wear, surface roughness and dimensional deviation, *Journal of Material Processing Technology*, 123(3), 483-489.
- Ezugwu, E.O., Bonney, J., Rosemar, B., Silva, D. and Çakir, O., 2007. Surface integrity of finished turned Ti-6Al-4V alloy with PCD tools using conventional and high pressure coolant supplies, *International Journal of Machine Tools and Manufacture* 47(6), 884-891.
- Gill, S. S., Singh, H., Singh, R. and Singh, J., 2010. Cryoprocessing of cutting tool materials—a review, *International Journal of Advanced Manufacturing Technology*, 48(1-4), 175-192.
- Hong, S. Y., 2001. Economical and ecological machining, *Journal of Manufacturing Science and Engineering*, 123(2), 331-338.
- Hong, S. Y. and Ding, Y., 2001. Cooling approaches and cutting temperatures in cryogenic machining of Ti-6Al-4V, *International Journal of Machine Tools and Manufacture*, 41 (10), 1417-1437.
- Hong, S. Y. and Ding, Y., 2001. Micro-temperature manipulation in cryogenic machining of low carbon steel, *Journal of Material Processing Technology*, 116 (1-3), 22-30.
- Hong, S. Y., Ding, Y. and Ekkens, R. D., 1999. Improving low carbon steel chip breakability by cryogenic chip cooling, *International Journal of Machine Tools and Manufacture*, 39 (7), 1065-1085.
- Hong, S. Y., Markus, I. and Jeong, W., 2001. New cooling approach and tool life improvement in cryogenic machining of titanium alloy Ti-6Al-4V, *International Journal of Machine Tools and Manufacture*, 41 (15), 2245-2260.
- Jaharah, A. G., Choudhury, I. A., Masjuki, H. H. and Che Hassan, C. H., 2009. Surface Integrity of AISI H13 Tool Steel in End Milling Process, *International Journal of Mechanical and Materials Engineering*, 4 (1), 88-92.
- Kalia, S., 2010. Cryogenic Processing: A Study of Materials at Low Temperatures, *Journal of Low Temperature Physics*, 158 (5-6), 934-945.
- Khan, A. A. and Ahmed M. I., 2008. Improving tool life using cryogenic cooling, *Journal of Material Processing Technology*, 196 (1-3), 149-154.
- Shaw M. A. 1986 *Metal Cutting Principles*. Oxford University Press, Oxford, 1986.
- SubsTech, 2010. Substances and Technologies: Stainless Steel AISI 304, [http://www.substech.com/dokuwiki/doku.php?id=stainless\\_steel\\_aisi\\_304](http://www.substech.com/dokuwiki/doku.php?id=stainless_steel_aisi_304), (10 April 2010).
- Suleiman, A., Khan, A. A. and Konneh, M., 2009. Reducing electrode wear ratio using cryogenic cooling during electrical discharge machining, *International Journal of Advanced Manufacturing Technology*, 45 (11-12), 1146-1151.
- Vadivel, K. and Rudramoorthy, R., 2009. Performance analysis of cryogenically treated coated carbide inserts, *International Journal of Advanced Manufacturing Technology*, 42 (3-4), 222-232.
- Wang, Z. Y. and Rajurkar, K. P., 2000. Cryogenic machining of hard-to-cut materials, *Wear*, 239 (2), 168-175.
- Yakup, Y., Muammer, N., 2008. A review of cryogenic cooling in machining processes, *International Journal of Machine Tools and Manufacture*, 48 (9), 947-964.
- Zurecki, Z., Ghosh, J.H. and Frey, J. H., 2003. Finish turning of hardened powder-metallurgy steel using cryogenic cooling, *Proceedings of the International Conference on Powder Metallurgy and Particulate Materials*, Las Vegas.