

Intelligent Sliding Mode Controller for Active Suspension System Using Particle Swarm Optimization

Mahmood Ali Moqbel Obaid^{a,b*}, Abdul Rashid Husain^a, Ali Abdo Mohammed Al-kubati^b

^aFaculty of Electrical Engineering, Universiti Teknologi Malaysia, 81310 UTM Johor Bahru, Johor, Malaysia

^bFaculty of Computer Science and Engineering, Hodeidah University, Yemen

*Corresponding author: eng_mahkah192@yahoo.com

Article history

Received :30 October 2013

Received in revised form :

5 May 2014

Accepted :15 June 2014

Graphical abstract

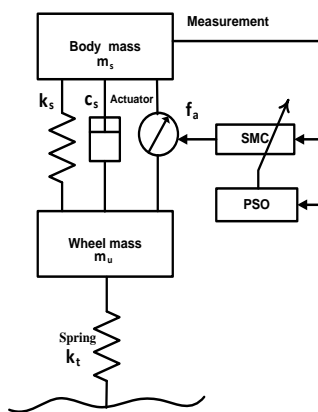

Abstract

This paper considers the control of an active suspension system (ASS) for a quarter car model based on the fusion of robust control and computational intelligence techniques. The objective of designing a controller for the car suspension system is to improve the ride comfort while maintaining the constraints on to the suspension travel and tire deformation subjected to different road profile. However, due to the mismatched uncertainty in the mathematical model of the ASS, sliding mode control (SMC) cannot be applied directly to control the system. Thus, the purpose of this work is to adapt the SMC technique for the control of ASS, where particle swarm optimization (PSO) algorithm is utilized to design the sliding surface such that the effect of the mismatched uncertainty can be minimized. The performance of the proposed sliding mode controller based on the PSO algorithm is compared with the linear quadratic optimal control (LQR) and the existing passive suspension system. In comparison with the other control methods, the simulation results demonstrate the superiority of the proposed controller, where it significantly improved the ride comfort 67% and 25% more than the passive suspension system and the LQR controller, respectively.

Keywords: Active suspension system; sliding mode control; particle swarm optimization; mismatched uncertainty

Abstrak

Kertas ini menjelaskan tentang kawalan dalam Sistem Suspensi Aktif (SSA) untuk model kereta suku berdasarkan gabungan sistem kawalan mantap dan teknik pengiraan pintar. Objektif dalam merekabentuk sistem kawalan dalam sistem suspensi kereta ini adalah untuk meningkatkan keselesaan perjalanan dan dalam masa yang sama mengekalkan kekangan ke perjalanan penggantung dan perubahan bentuk tayar mengikut profil permukaan jalan. Walau bagaimanapun, disebabkan oleh ketidakpastian tak terpadan dalam model matematik SSA, Mod Kawalan Gelangsar (MKG) tidak boleh digunakan secara langsung untuk mengawal sistem. Oleh itu, tujuan kajian ini adalah untuk mengaplikasikan teknik MKG bagi mengawal SSA di mana Algoritma Pegoptimuman Zarah Kumpulan (APZK) digunakan untuk merekabentuk permukaan gelangsar supaya kesan ketidakpastian tak terpadan dapat dikurangkan. Prestasi mod gelangsar pengawal yang dicadangkan berdasarkan algoritma APZK dibandingkan dengan Pengawal Lelurus Kuadratik (PLK) dan sistem suspensi pasif yang sedia ada. Apabila dibandingkan dengan kaedah kawalan yang lain, keputusan simulasi menunjukkan bahawa pengawal yang dicadangkan sangat efektif di mana prestasi keselesaan pemanduan meningkat sebanyak 67% berbanding sistem suspensi pasif dan 25% berbanding PLK.

Kata kunci: Sistem suspensi aktif; mod kawalan gelangsar; algoritma pegoptimuman zarah kumpulan; ketidakpastian tak terpadan

© 2014 Penerbit UTM Press. All rights reserved.

1.0 INTRODUCTION

A car suspension system is the mechanism that physically separates the car body from the car wheels. A conventional passive car suspension model is always a trade-off between the ride comfort and road handling. However, an active suspension system (ASS) differs from the conventional car suspensions in its ability to store, dissipate and to introduce energy to the system. Figure 1 shows the schematic

view of the ASS, where the hydraulic actuator is installed in parallel with the passive components. The main function of ASS is to efficiently improve the control performance and the ride comfort for passengers in a vehicle. Typically, a high-quality ASS can isolate the car body from the vibration arising from road surface. Furthermore, it ensures the contact between the wheels and road surface for a better ride comfort and safety. The objective of

designing an ASS is to manage the compromise between ride comfort and handling performance.

The improvement of a vehicle active suspension control system currently gains great interest in both academics and automobile industrial researches. Many control strategies have been recently proposed to manage the compromise between ride comfort and road handling performance of an ASS. These include Fuzzy logic control [1-3], propositional derivative (PD) control [4], optimal state feedback control [5], robust control [6], and sliding mode control [7]. An adaptive fuzzy control technique is presented in [8] to improve the riding quality of ASS. Similarly, a fuzzy logic controller is developed in [9] for four degrees of freedom non-linear ASS. In addition, an adaptive nonlinear controller is designed in [10] in order to reduce the model error of uncertain ASS. Some researchers suggested including the dynamic of the actuator to obtain an enhanced plant model and to improve overall system performance [11]. For instance, a hybrid fuzzy H_∞ controller is developed in [3] for uncertain quarter car ASS with considering actuator delay and failure.

Among the previous control techniques, the sliding mode control (SMC) is an effective nonlinear control technique for uncertain systems because it possesses many features, i.e., stability, insensitivity to model uncertainty, external disturbance rejection and good transient performance [12]. It has been widely applied to many practical systems, such as ASS [13], robotics [14], electrical drive [15] and Active Magnetic Bearing System [16]. Conventional SMC techniques require that the system uncertainties satisfy the matching conditions, so that the control input and the model uncertainty enter the state equations of the system at the same points. Many researchers have studied the SMC for a system with mismatched uncertainties [16-19]. The SMC for ASS is developed in [18] where the sliding vector is derived using LQR theory. A proportional-integral SMC is presented in [19] for ASS where the sliding surface is composed of two parts, the proportional and the integral parts. The results showed the obtained improvement on the ride comfort and road handling compared to the LQR method and the passive suspension system.

Although the extensive research has been done on the SMC theory and applications, but there are still some drawback with SMC, i.e., the chattering phenomenon, and the effect of the unmatched perturbation on the system during the sliding mode. The SMC can be combined with other robust methods such as soft computing techniques in order to reduce efficiently the effect of mismatched perturbations [17]. The purpose of this work is to adapt the SMC technique for the control of ASS where particle swarm optimization (PSO) algorithm is utilized to design the sliding surface such that the effect of the mismatched uncertainty can be minimized. Different from that in the literature, the optimal values of the switching vector of the SMC in this paper is optimized using PSO algorithm, so that the reaching and sliding condition of the SMC is guaranteed in the presence of the mismatched uncertainty.

The paper is outlined as follows: In section 2, the model of the quarter car ASS is illustrated. Sections 3 and 4 give an overview of the SMC technique and PSO algorithm respectively. Section 5 describes the controller design that guarantees the reaching and sliding condition. Section 6 discusses how PSO algorithm is incorporated to reduce the effect of the mismatched. The results of the designed controller as compared to LQR and passive suspension system are discussed in section 7. Finally, the conclusion is presented in section 8.

2.0 QUARTER CAR MODEL

Based on the study [19], a quarter car suspension model is used in this paper. The model is shown in Figure 1, and the parameters used

are tabulated in Table 1. The dynamic equations of the two-degree-of-freedom quarter car suspension system are of the following form.

$$m_s z_s'' = k_s(z_u - z_s) + b_s(z_u' - z_s') + f_a \tag{1}$$

$$m_u z_u'' = -k_s(z_u - z_s) - b_s(z_u' - z_s') + k_t(z_r - z_u) - f_a \tag{2}$$

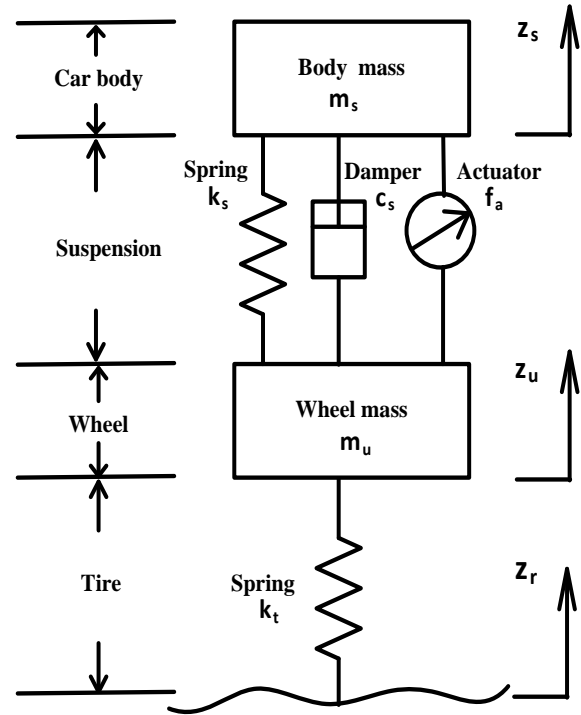

Figure 1 Quarter-car active suspension model

The motion equations of the quarter car model for the active suspension are given by the following state space representation.

Table 1 The parameters of quarter car model

Parameter	Description
m_s	sprung mass = 282 kg
m_u	unsprung mass = 45 kg
k_s	spring constant = 17900 N/m
k_t	spring constant of tire = 165790 N/m
b_s	damper coefficient = 1500 N/(m/s)
Z_s	displacement of vehicle chassis relative to plain ground
Z_u	displacement of wheel relative to plain ground
Z_r	uneven road surface relative to plain ground
f_a	output force provided by the servo-hydraulic cylinder.

$$\begin{bmatrix} \dot{x}_1 \\ \dot{x}_2 \\ \dot{x}_3 \\ \dot{x}_4 \end{bmatrix} = \begin{bmatrix} 0 & 1 & 0 & -1 \\ -k_s & -b_s & 0 & b_s \\ m_s & m_s & 0 & m_s \\ 0 & 0 & 0 & 1 \\ k_s & b_s & -k_t & -b_s \\ m_u & m_u & m_u & m_u \end{bmatrix} \begin{bmatrix} x_1 \\ x_2 \\ x_3 \\ x_4 \end{bmatrix} + \begin{bmatrix} 0 \\ 1 \\ 0 \\ -1 \\ 0 \\ m_u \end{bmatrix} f_a + \begin{bmatrix} 0 \\ 0 \\ -1 \\ 0 \end{bmatrix} z_r \tag{3}$$

Where, f_a is the control force from the hydraulic actuator and assumed as the control input. In general Equation (3) can be written in a compact form as:

$$\dot{x}(t) = Ax(t) + Bu(t) + f(x, t) \tag{4}$$

Where $x(t) \in R^{n \times m}$ is the state vector, $u(t) \in R^{m \times n}$ is the control input, and the continuous function $f(x, t)$ represents the uncertainties with the mismatched condition.

It can be seen from Equation (3) that the input f_a is not in the range space of the disturbance input z_i . By having this mismatched condition, it impose a new challenging condition in control design in which the control not only has to be able to ensure the tracking performance, but it also should incorporate the mismatched disturbance removal to achieve high tracking accuracy. Thus, in order to simplify the analysis, the following assumptions are made:

Assumption 1. There exists an $\beta > 0$ such that $\|f(x, t)\| \leq \beta$, where $\|\cdot\|$ represented the standard Euclidian norm.

Assumption 2. The pair (A, B) is controllable and the input matrix B has a full rank.

3.0 SLIDING MODE CONTROL (SMC)

As a class of variable structure controller, the SMC was first proposed in 1950's in Russia by Emelyanov and other researchers at the Institute of Control Problems (IPU). This robust control technique had become popular after it was published by Itkis [20] and Utkin[21]. SMC is a nonlinear control technique which it has many attractive features such as its robustness to model uncertainty that satisfy the matching condition. The design of SMC controller involves two crucial steps which are commonly referred to as the reaching phase and the sliding phase [16]. SMC strategy is used to force the system state to reach and subsequently remains on a predefined surface within the state space. In order to achieve these strategies, the design procedure of the SMC scheme is broken into two main phases:

- (1) The sliding surface is designed in the state space such that the sliding motion of the reduced order system satisfies the specified performance.
- (2) The control law synthesis so that the motion trajectories of the closed loop system are directed toward the sliding surface.

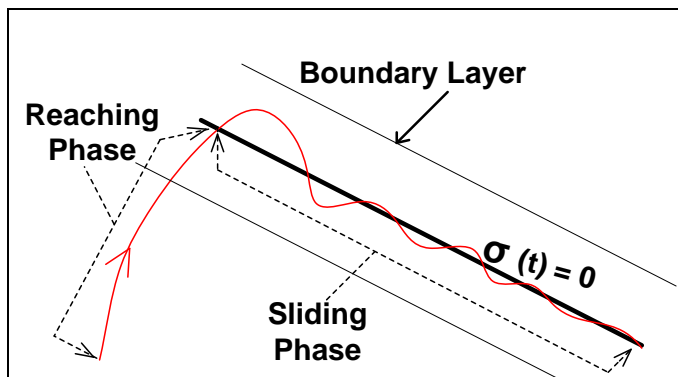

Figure 2 SMC scheme

The conventional sliding surface $\sigma(t)$ is defined as:

$$\sigma(t) = Cx(t)$$

Where $C \in R^{m \times n}$ is a full rank constant matrix, m is the number of input and n is the number of system states. The matrix C is chosen such that $CB \in R^{m \times n}$ is nonsingular. The main

contribution of this paper is to adapt the conventional SMC for control of a system with mismatched uncertainty. By having this mismatched condition, the switching vector of the sliding surface should be carefully selected so that the effect of the mismatched uncertainty can be minimized [22]. The SMC can be combined with other robust techniques such as PSO algorithm in the design of the sliding surface, as described later, to overcome the limitation of conventional SMC against mismatched uncertainty.

4.0 PARTICLE SWARM OPTIMIZATION (PSO) ALGORITHM

PSO algorithm is a population based optimization method that was originally developed by Kennedy and Eberhart in 1995 [23]. PSO algorithm is initialized with a population of random individuals (particles) represent the possible solutions. Then, PSO searches in these particles for optimal solution. The position and the velocity of each particle are updated in each iteration according to its previous best position. Each individual particle has a current position x_i , velocity v_i , and personal best position ($x_{idpbest}$). The position amongst all the particles' personal best positions that yielded the smallest error is called the global best position ($x_{idgbest}$). The particle's velocity is updated during each iteration and the new velocity is added to the particle's current position to determine its new position.

The velocity and the position of each particle are updated according to the following equations [24]:

$$w(t) = w_{\min} + (w_{\max} - w_{\min}) \left(\frac{m-t}{m-1} \right) \quad (5)$$

$$v_{id}(t) = w(t)v_{id}(t-1) + 2\alpha(x_{idpbest}(t-1) - x_{id}(t-1)) + 2\alpha(x_{idgbest}(t-1) - x_{id}(t-1)) \quad (6)$$

$$x_{id}(t) = v_{id}(t) + x_{id}(t-1) \quad (7)$$

Where, w_{\min} and w_{\max} are the maximum and minimum values of the inertia weight w , $v_{id}(t)$ is the velocity of the particle i at iteration t , $x_{id}(t)$ is the current position of particle i at iteration t , m is the maximum number of iterations, i is the number of the particles that goes from 1 to n , d is the dimension of the variables, and α is a uniformly distributed random number in $(0,1)$.

The described PSO algorithm is utilized to design the sliding surface in such a way that the effect of mismatched uncertainty can be minimized. Therefore, the reaching and sliding condition of the SMC is guaranteed in the presence of the mismatched uncertainty. Then, the SMC based PSO algorithm is applied to an ASS to reject the effect of road disturbances, where the fitness function is given as Equation (17). The dimension of each particle is equal to the number of the system state. This will result in a total of 4 parameters to be optimized using the proposed PSO based approach.

5.0 CONTROLLER DESIGN

The controller utilized a SMC based PSO algorithm scheme to reject the effect of road disturbances. The flowchart of Figure 3 describes the steps used in designing the proposed controller. The inputs of the controller are wheel velocity and the vehicle body velocity, whereas the output of the controller is the target force that must be exerted by the hydraulic actuator.

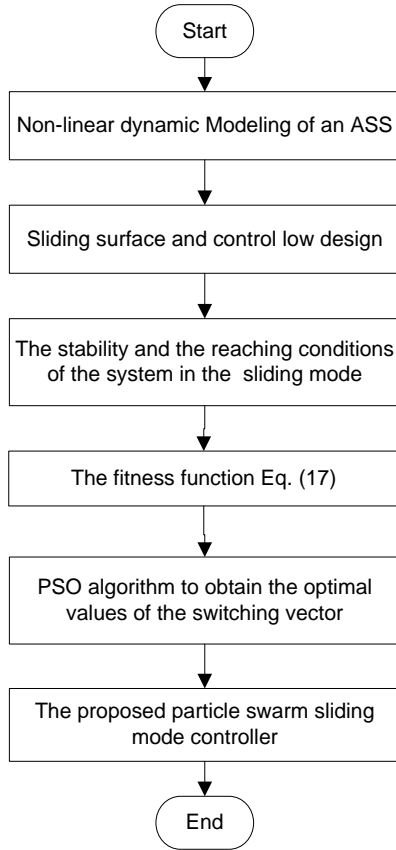

Figure 3 The steps used in designing the proposed controller

The SMC surface of a quarter car ASS is defined as follows:

$$\sigma(t) = Cx(t) \tag{8}$$

The control input of the SMC can be written as

$$u(t) = u_{eq}(t) + u_s(t) \tag{9}$$

Where $u_s(t)$ is the nonlinear switching part of the controller that used to direct the system state toward the sliding surface and $u_{eq}(t)$ is the equivalent controller which obtains by letting $\sigma(t) = 0$ [19].

$$\sigma(t) = Cx(t) = 0 \tag{10}$$

If the matrix C is chosen such that CB is nonsingular, this yields:

$$u_{eq}(t) = - (CB)^{-1} (CAx(t) + Cf(x, t)) \tag{11}$$

Substituting Equation (11) into system Equation (4) gives the equivalent dynamic of the system in the sliding mode as:

$$\dot{x}(t) = (A - B(CB)^{-1}CA)x(t) + \{I_n - B(CB)^{-1}C\}f(x, t) \tag{12}$$

The switching controller $u_s(t)$ is selected as follow [19]:

$$u_s(t) = (CB)^{-1} \rho \frac{\sigma(t)}{\|\sigma(t)\| + \delta} \tag{13}$$

Where δ is the boundary layer thickness that is selected to reduce the chattering problem and $\rho > 0$ is a selected parameter that specified by the designer.

Therefore, the proposed sliding mode controller given as follows:

$$u(t) = u_{eq}(t) + u_s(t) \tag{14}$$

$$u(t) = - (CB)^{-1} [CAx(t) + Cf(x, t) + \rho \frac{\sigma(t)}{\|\sigma(t)\| + \delta}] \tag{15}$$

The optimal value for the matrixes C in Equation (8) to Equation (15) is chosen by PSO, where the fitness function is given by Equation (17). The state trajectories that are driven by the above controller will slide on the design sliding surface if the reaching condition $\sigma(t)\dot{\sigma}(t) < 0$ is satisfied [19].

$$\sigma(t)\dot{\sigma}(t) = \sigma(t) \left[-\rho \frac{\sigma(t)}{\|\sigma(t)\| + \delta} \right] < 0 \tag{16}$$

Equation (16) shows that the hitting condition of the sliding surface Equation (10) is satisfied if $\rho > 0$.

6.0 SMC DESIGN BASED ON PSO

PSO algorithm is proposed to search for the optimal values of the switching vector (matrix C). The car body acceleration is considered as fitness function. The objective of the optimization is to minimize the fitness function performance index as:

$$J = \int_0^T \bar{y}(t)^2 dt \tag{17}$$

Where, $\bar{y}(t)$ is the acceleration of the car body and T is the integral period time.

The active suspension model described in section 2 has four state variables and one control input. The flowchart of Figure 4 describes the implementation of PSO algorithm for the optimal selection of the switching vector.

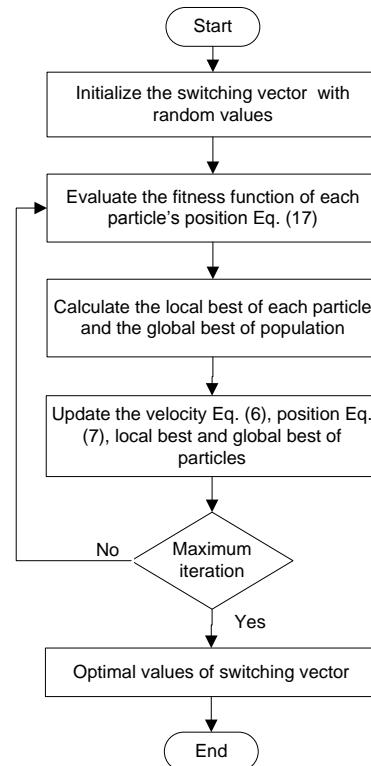

Figure 4 SMC design based on PSO algorithm

The switching vector of the proposed sliding mode controller will be represented by:

$$C^T = [C_{11} \ C_{12} \ C_{13} \ C_{14}] \tag{18}$$

This will result in a total of 4 parameters to be optimized using the proposed PSO based approach.

7.0 RESULT AND DISCUSSION

This section discusses the simulation results of the proposed particle swarm SMC for the mathematical model of the system as defined in Equation (3). The proposed sliding mode controller in Equation (15) and the mathematical model of the system as defined in Equation (3) are simulated in MATLAB-SIMULINK. The parameters of the quarter car suspension model selected for this study are listed in Table 2.

Table 2 Parameters value used in a quarter car suspension system

Parameter	Value
m_s	282 kg
k_s	17900 N/m
b_s	1500 N/(m/s)
k_t	165790 N/m
m_u	45 kg

The road disturbance z_r used in this simulation is represented by a bump as shown in Figure 5.

$$z_r = \begin{cases} 0.025(1 - \cos 8\pi t), & 0.5 \text{ sec} \leq t \leq 0.75 \text{ sec} \\ 0, & \text{otherwise} \end{cases}$$

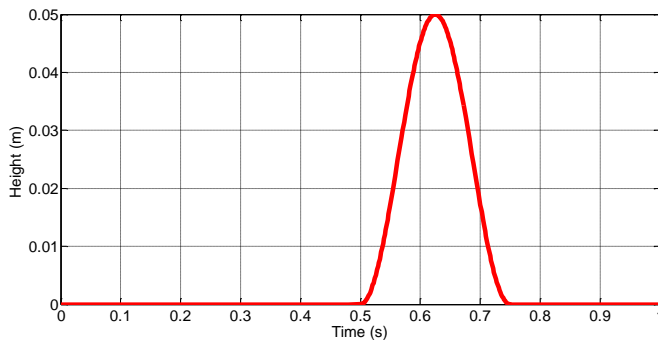

Figure 5 A single bump road disturbance

The simulation was performed for a period of 3 second with a variable step size using ode45 (Dormand-Prince) solver. There are two parameters to be observed in this study namely, the car body acceleration and the wheel deflection. The main objective is to minimize the car body acceleration for ride comfort by maintaining the following constrains:

1. Suspension travel limit is ± 8 cm [25].
2. Maximum tire deflection

$$(x_u - x_r) \leq \frac{9.8 * (m_s + m_u)}{k_t} = 1.9 \text{ cm} \tag{26}$$

3. Spool valve displacement limits ± 1 cm
4. Force limits (1000N) [25].

The performance of the particle swarm SMC is compared with the LQR controller and the existing passive suspension system. The values of Q and R for the LQR controller are obtained by the proposed PSO algorithm. The number of particle in each swarm is set to 20 and the maximum number of iteration is set to 70. The PSO search process should be terminated when there is no improvement in the value of the fitness function for a particular number of iterations or the maximum number of iterations is reached.

$$Q = \begin{bmatrix} 0.8285 & 0 & 0 & 0 \\ 0 & 1 & 0 & 0 \\ 0 & 0 & 0.01 & 0 \\ 0 & 0 & 0 & 0.01 \end{bmatrix} * 10^5$$

$$R = 51 * 10^{-4}$$

Using Matlab the poles and state feedback gains for the LQR controller are as follows:

$$\text{Poles} = \begin{bmatrix} -17.3362 + 59.8921i \\ -17.3362 - 59.8921i \\ -7.7912 + 0.9783i \\ -7.7912 - 0.9783i \end{bmatrix}$$

$$K_{lqr} = [448 \ 3300 \ -14963 \ 5]$$

The optimal values of the switching surface C of the proposed particle swarm SMC is given as follow:

$$C = [15.3119 \ 4.4 \ -1.4596 \ 0.0215]$$

These values of C are obtained by the proposed PSO algorithm with maintaining the constraints of the suspension system. The number of particle in each swarm is set to 10 and the maximum number of iteration is set to 15. The boundary layer thickness δ and the sliding gain ρ are set as following:

$$\delta = 200$$

$$\rho = 300$$

The sliding surface obtained from the simulation is shown in Figure 6. The simulation result shows that the trajectories of the system state at $t=2.4$ seconds it starts to hit the surface and remains on the surface. Therefore, the reaching and hitting conditions of the sliding surface is observed.

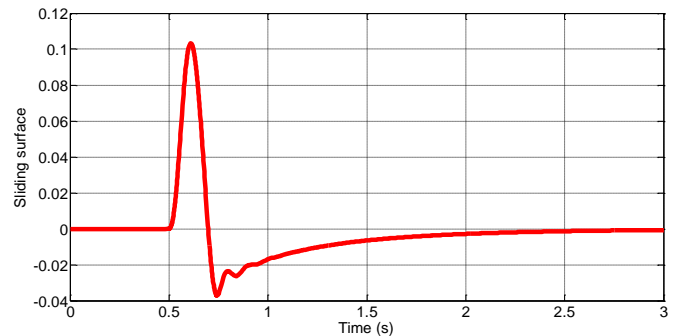

Figure 6 Sliding surface of SMC

The convergence of the fitness function of the proposed PSO algorithm for both SMC and LQR controllers are shown in Figure 7. It can be observed that the convergence of the fitness function of the proposed SMC is much faster than LQR. Moreover, the fitness value of the proposed SMC converges to zero with less iterations compared with LQR controller.

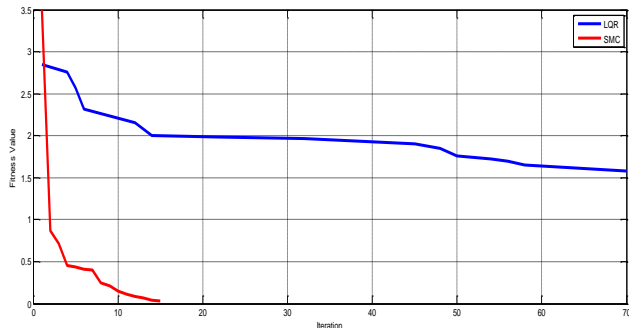

Figure 7 Convergence of the fitness function for SMC and LQR

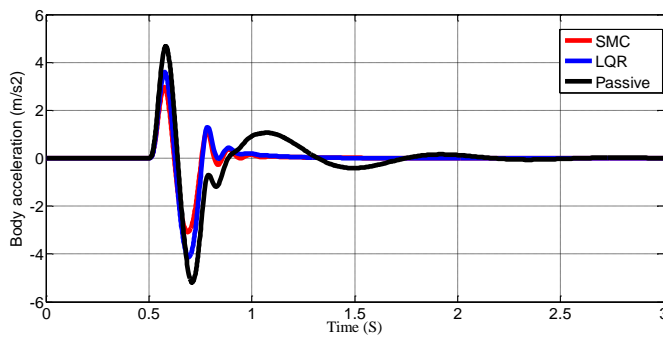

Figure 8 Unsprung mass acceleration

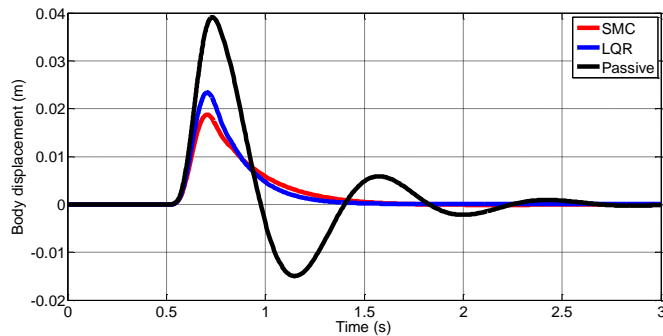

Figure 9 Unsprung mass displacements

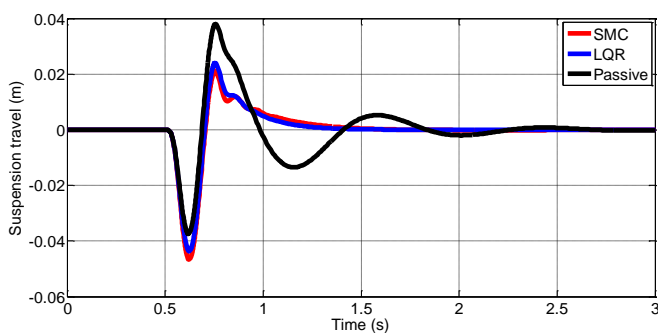

Figure 10 Suspension travel

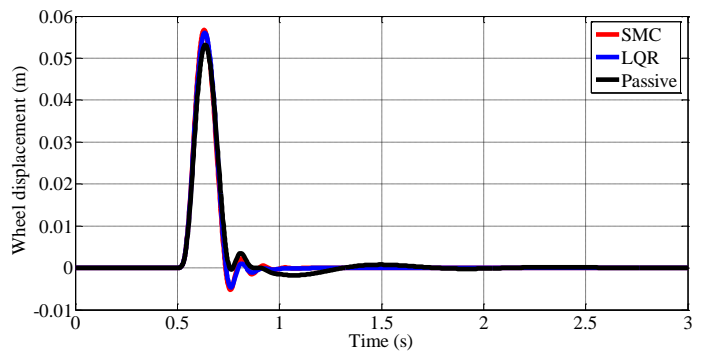

Figure 11 Wheel displacement

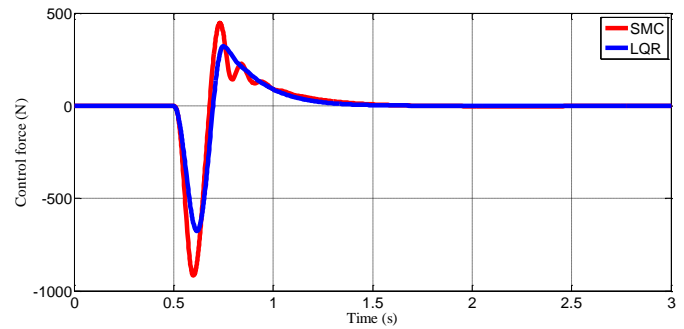

Figure 12 Control force

Table 3 Comparison of maximum peak value and settling time for bump response

Controller type	Passive controller		LQR-based PSO		SMC-based PSO	
	Peak value	T_s	Peak value	T_s	Peak value	T_s
System response						
Car body acceleration	4.67	2.1	3.6	1.2	2.9	1.1
Suspension travel	0.0374	2.5	0.0437	1.3	0.0467	1.4
Wheel displacement	0.0532	1.5	0.0561	0.81	0.0567	0.82
Control force	0	0	676	1.32	917.46	1.4

Figures 8-12 show, respectively, the responses of the unsprung mass acceleration, unsprung mass displacements, suspension travel, wheel displacement, and control force. To clearly show the results, the maximum peak values and the settling times (T_s) for unsprung mass acceleration, suspension travel, wheel displacement, and control force are listed in Table 3. From Table 3, it can be seen that the unsprung mass acceleration and displacement are reduced in the two cases (SMC based PSO and LQR) compared to the passive suspension system. Furthermore, the designed SMC based PSO provides a significant improvement in ride comfort compared to LQR controller. As Figure 8 shows, the peak value of body acceleration which is a measure of ride quality is reduced from 3.6 m/s^2 in the case of LQR controller into 2.9 m/s^2 using the designed SMC based PSO algorithm. The car body displacement is shown in Figure 9. It can be observed that the car displacement is much reduced in ASS (SMC based PSO and LQR) compared to the passive suspension system. In addition, the car displacement using

the proposed SMC based PSO is smoothly changed which provides a better ride comfort. Using the designed SMC based PSO algorithm, the ride comfort can be improved by 67% and 25% over the passive suspension system and the LQR controller respectively.

Figures 10 and 11 show the performance of suspension travel and wheel displacement, respectively. There is a small increment in the suspension travel and wheel displacement in the two cases (SMC based PSO and LQR) compared to the passive suspension system, but they are still in their limits (suspension travel limit and tire displacement limit). Therefore, the constraints of suspension travel limit as well as maximum tire deflection are guaranteed. Similarly, as shown in Figure 12 the control force does not exceed the limit of the hydraulic actuator (1000 N) in the two cases. The vibrations of unsprung mass, suspension system, and wheel displacement are settled faster by the ASS.

8.0 CONCLUSION

This paper proposed a particle swarm SMC for a system with mismatched disturbance and it has been applied to a quarter car ASS. The PSO algorithm is adopted to search for the optimal value of the sliding surface by using the body acceleration as a fitness function, so that the reaching and sliding condition of the SMC is guaranteed. The particle swarm SMC is compared with the LQR controller and the existing passive suspension system and it has shown better performance. The results show that the proposed controller improves the ride comfort by maintaining the other constraints (the suspension travel, tire deflection, and control force) in their limits. As future work, the SMC with PSO algorithm can be applied to the suspension system with considering sensor and actuator fault, as this area is becoming more important in parallel with sophistication of suspension technology.

References

- [1] Lin, J. and R.-J. Lian. 2013. Design of a Grey-prediction Self-organizing Fuzzy Controller for Active Suspension Systems. *Applied Soft Computing*. 13(10): 4162–4173.
- [2] Wang, W.-Y., M.-C. Chen, and S.-F. Su. 2012. Hierarchical Fuzzy-neural Control of Anti-lock Braking System and Active Suspension in a Vehicle. *Automatica*. 48(8): 1698–1706.
- [3] Hongyi, L., Honghai, L., G. Huijun, and S. Peng. 2012. Reliable Fuzzy Control for Active Suspension Systems with Actuator Delay and Fault. *IEEE Transactions on Fuzzy Systems*. 20(2): 342–357.
- [4] Jiongfang, L., et al. 2013. Active Suspension System Based on Linear Switched Reluctance Actuator and Control Schemes. *IEEE Transactions on Vehicular Technology*. 62(2): 562–572.
- [5] Chen, S., He, R., H. Liu, and M. Yao. 2012. Probe into Necessity of Active Suspension Based on LQG Control. *Physics Procedia*. 25(0): 932–938.
- [6] Van der Sande, T.P.J., et al. 2013. Robust Control of an Electromagnetic Active Suspension System: Simulations and Measurements. *Mechatronics*. 23(2): 204–212.
- [7] Ruey-Jing, L. 2013. Enhanced Adaptive Self-Organizing Fuzzy Sliding-Mode Controller for Active Suspension Systems. *IEEE Transactions on Industrial Electronics*. 60(3): 958–968.
- [8] Sharkawy, A. B. 2005. Fuzzy and Adaptive Fuzzy Control for the Automobiles' Active Suspension System. *Vehicle System Dynamics: International Journal of Vehicle Mechanics and Mobility*. 43(11): 795–806.
- [9] L. E. Sakman, R. Guclu, and N. Yagiz. 2005. Fuzzy Logic Control of Vehicle Suspensions with Dry Friction Nonlinearity. *Shadhana*. 30(5): 649–659.
- [10] Alleyne A, Hedrick, J. K. 1995. Nonlinear Adaptive Control of Active Suspensions. *IEEE Trans Control Syst Technol*. 3(1):94–101.
- [11] Y. M. Sam and J. H. S. Osman. 2006. Sliding Mode Control of a Hydraulically Actuated Active Suspension. *Jurnal Teknologi*.
- [12] Chiu-Keng, L. and S. Kuo-Kai. 2005. A Novel Motor Drive Design for Incremental Motion System via Sliding-mode Control Method. *IEEE Transactions on Industrial Electronics*. 52(2): 499–507.
- [13] Hongyi, L., Jinyong, Y., C. Hilton, and L. Honghai. 2013. Adaptive Sliding-Mode Control for Nonlinear Active Suspension Vehicle Systems Using T-S Fuzzy Approach. *IEEE Transactions on Industrial Electronics*. 60(8): 3328–3338.
- [14] Defoort, M., Floquet, T., A. Kokosy, and W. Perruquetti. 2008. Sliding-Mode Formation Control for Cooperative Autonomous Mobile Robots. *IEEE Transactions on Industrial Electronics*. 55(11): 3944–3953.
- [15] Kuo-Kai, S., L. Chiu-Keng, and J.Y. Hung. 2001. Totally Invariant State Feedback Controller for Position Control of Synchronous Reluctance Motor. *IEEE Transactions on Industrial Electronics*. 48(3): 615–624.
- [16] Husain, A. R., M. N. Ahmad, and A. H. M. Yatim. 2008. Application of H₂-based Sliding Mode Control for an Active Magnetic Bearing System. *International Journal of Mechanical System Science and Engineering*. 2(1): 1–8.
- [17] Yu, X., and Kaynak, K. 2009. Sliding Mode Control with Soft Computing: A Survey. *IEEE Transactions on Industrial Electronics*. 56(9): 3275–3285.
- [18] Yoshimura, T., Kume, A., M. Kurimoto, and J. Hino. 2001. Construction of an Active Suspension System of a Quarter Car Model Using the Concept of Sliding Mode Control. *Journal of Sound and Vibration*. 239(2): 187–199.
- [19] Y. M. Sam, K. Hudha, and J. H. S. Osman. 2007. PI/PISMC Control of Hydraulically Actuated Active Suspension System. *International Journal of Vehicle System Modeling and Testing*. 2(4): 391–410.
- [20] Itkis, U. 1976. *Control Systems of Variable Structure*. New York:Wiley.
- [21] Utkin, V. 1977. Variable Structure Systems with Sliding Modes. *IEEE Transactions on Automatic Control*. 22(2): 212–222.
- [22] Castanos, F. and L. Fridman. 2006. Analysis and Design of Integral Sliding Manifolds for Systems with Unmatched Perturbations. *IEEE Transactions on Automatic Control*. 51(5): 853–858.
- [23] Kennedy, J., and Eberhart, R. 1995. Particle Swarm Optimization. Purdue School of Engineering and Technology. *Indianapolis*. IN 46202–5160.
- [24] Lin, D., Qiu, S., and Wang, D. 2008. Particle Swarm Optimization Based on Neighborhood Encoding for Traveling Salesman Problem. *IEEE International Conference on Systems, Man and Cybernetics*.
- [25] Jung, L. and K. Ioanni. 1997. Nonlinear Design of Active Suspensions. *IEEE Control Systems*. 17(3): 45–59.
- [26] Gao, H., Lam, J., and Wang, C. 2006. Multi-objective Control of Vehicle Active Suspension Systems via Load-dependent Controllers. *Journal of Sound and Vibration*. 290(3–5): 654–675.